

Write your name here	
Surname	Other names
Centre Number	Candidate Number
<input type="text"/>	<input type="text"/>
Edexcel GCE	
Physics	
Advanced Subsidiary	
Unit 2: Physics at Work	
Thursday 15 January 2009 – Afternoon Time: 1 hour 20 minutes	Paper Reference 6PH02/01
You must have: Ruler	Total Marks

Instructions

- Use **black** ink or ball-point pen.
- **Fill in the boxes** at the top of this page with your name, centre number and candidate number.
- Answer **all** questions.
- Answer the questions in the spaces provided
– *there may be more space than you need.*

Information

- The total mark for this paper is 80.
- The marks for **each** question are shown in brackets
– *use this as a guide as to how much time to spend on each question.*
- Questions labelled with an **asterisk** (*) are ones where the quality of your written communication will be assessed
– *you should take particular care with your spelling, punctuation and grammar, as well as the clarity of expression, on these questions.*
- The list of data, formulae and relationships is printed at the end of this booklet.
- Candidates may use a scientific calculator.

Advice

- Read each question carefully before you start to answer it.
- Keep an eye on the time.
- Try to answer every question.
- Check your answers if you have time at the end.

Turn over ►

N34432A

©2009 Edexcel Limited.
1/1/1/1/1/2



edexcel 
advancing learning, changing lives

SECTION A

Answer ALL questions.

For questions 1–10, in Section A, select one answer from A to D and put a cross in the box ☒.
If you change your mind, put a line through the box ☒ and then mark your new answer with a cross ☒.

- 1 A child's toy is operated by a small motor. The potential difference across the motor is 6.0 V and the current in it is 0.20 A. The energy used by the motor in 120 s is

- A 2.40 J
 B 60.0 J
 C 144 J
 D 3600 J

(Total for Question 1 = 1 mark)

- 2 Which one of the following does **not** apply to sound waves?

- A They transmit energy.
 B They travel faster in a vacuum.
 C They result from vibrations.
 D They are longitudinal waves.

(Total for Question 2 = 1 mark)

- 3 Two coherent sources emit waves of wavelength λ in phase. At a point where the two waves meet they have a phase difference of 90° ($\frac{\pi}{2}$ radians). Which of the following could be the path difference at this point?

- A 2λ
 B λ
 C $\frac{\lambda}{2}$
 D $\frac{\lambda}{4}$

(Total for Question 3 = 1 mark)



4 The four diagrams show waves of different wavelengths approaching slits of different widths.

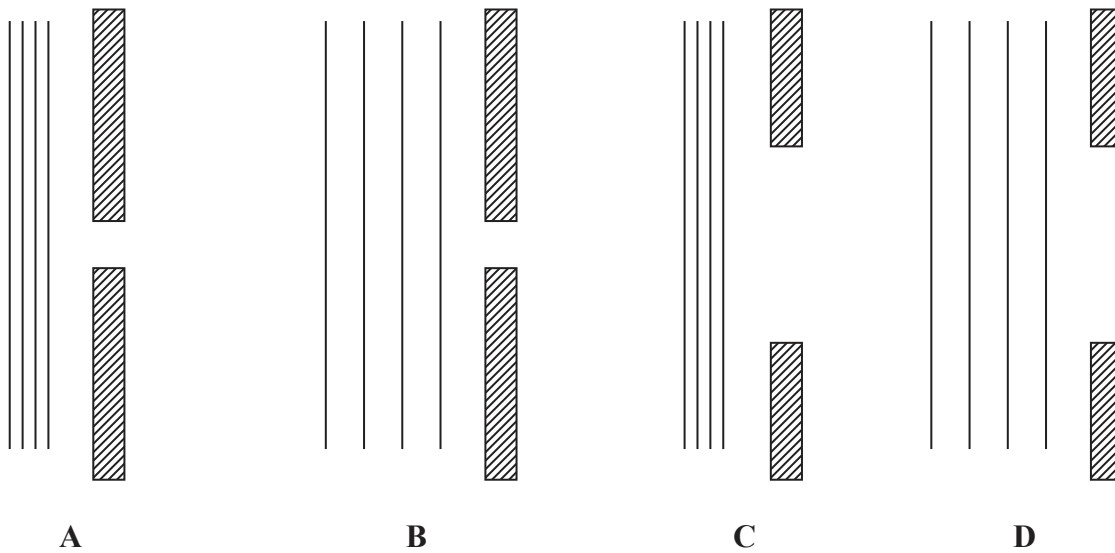

In which diagram will the diffraction be the greatest?

- A
- B
- C
- D

(Total for Question 4 = 1 mark)

5 The heating element for an electric fire is made from a wire of resistance R . It is replaced with a wire of the same material which has the same length but is twice the diameter. The resistance of this second wire is

- A $\frac{1}{4}R$
- B $\frac{1}{2}R$
- C $2R$
- D $4R$

(Total for Question 5 = 1 mark)



6 The diagram shows a resistor network.

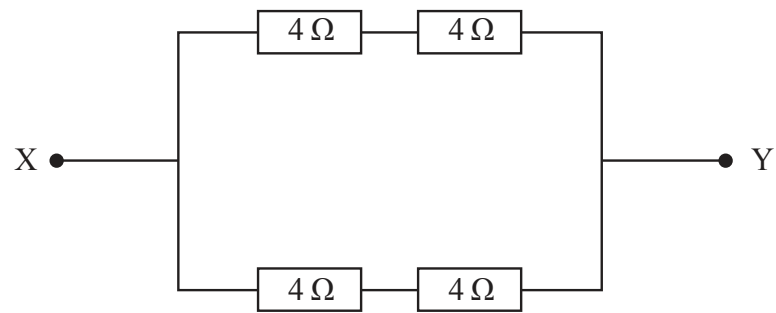

The total resistance between points X and Y is

- A $0.25\ \Omega$
- B $1.0\ \Omega$
- C $4.0\ \Omega$
- D $16\ \Omega$

(Total for Question 6 = 1 mark)

7 The speed of sound in steel is $6000\ \text{m s}^{-1}$. The wavelength of an ultrasound wave of frequency $50\ \text{kHz}$ travelling through a steel girder is

- A $0.0083\ \text{m}$
- B $0.12\ \text{m}$
- C $8.3\ \text{m}$
- D $120\ \text{m}$

(Total for Question 7 = 1 mark)



8 Which one of the following graphs correctly shows the relationship between potential difference (V) and current (I) for a filament lamp?

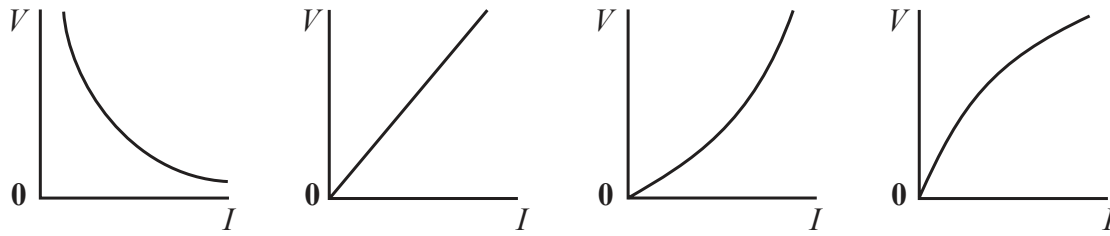

A

B

C

D

- A
- B
- C
- D

(Total for Question 8 = 1 mark)

9 Light travels into a semicircular glass block as shown in the diagram. The ray of light reaches the straight edge of the block at an angle of incidence i .

The critical angle for glass is c .

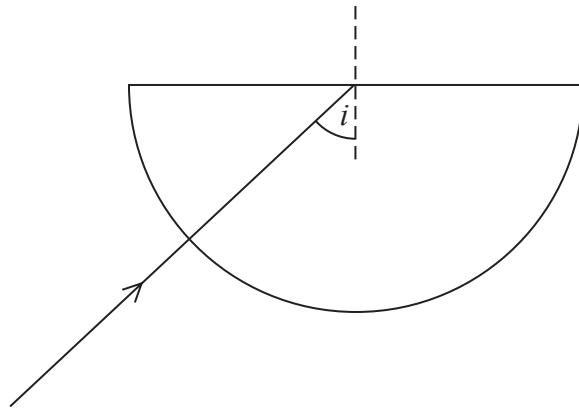

Which one of the following statements is true for light at the straight edge?

- A When i is bigger than c then no light is reflected.
- B When i is bigger than c then no light is transmitted.
- C When i is smaller than c then no light is reflected.
- D When i is smaller than c then no light is transmitted.

(Total for Question 9 = 1 mark)



10 When a fire engine moves away from an observer, the pitch of the siren heard by the observer decreases. This is because

- A the wavelength of the sound wave decreases
- B the speed of the fire engine increases
- C the frequency of the siren decreases
- D the distance travelled by each wavefront increases

(Total for Question 10 = 1 mark)

TOTAL FOR SECTION A = 10 MARKS



SECTION B

Answer ALL questions in the spaces provided.

- 11 Explain, in terms of energy, the difference between potential difference (p.d.) and electromotive force (e.m.f.).

(2)

.....

.....

.....

.....

(Total for Question 11 = 2 marks)

- 12 The diagram shows the shape of a wave on the surface of a tank of water at one instant of time. The wave is travelling to the right.

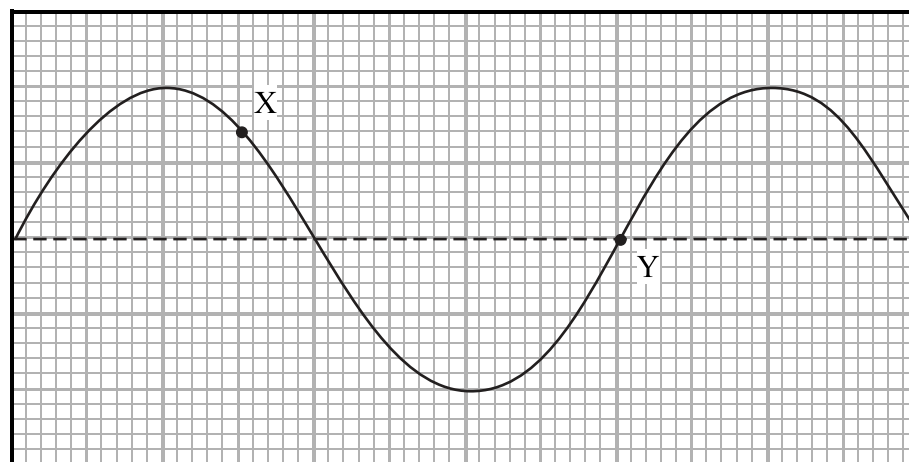

On the diagram

- (a) mark a point on the water surface whose motion is exactly 180° out of phase with the motion at X. Label this point A, (1)
- (b) draw an arrow at point Y to show the direction in which the water at Y is moving at the instant shown, (1)
- (c) mark a point on the water surface that is at rest at the instant shown. Label this point B. (1)

(Total for Question 12 = 3 marks)



13 (a) What is the coulomb in base units? (1)

(b) The diagram shows part of an electrical circuit.

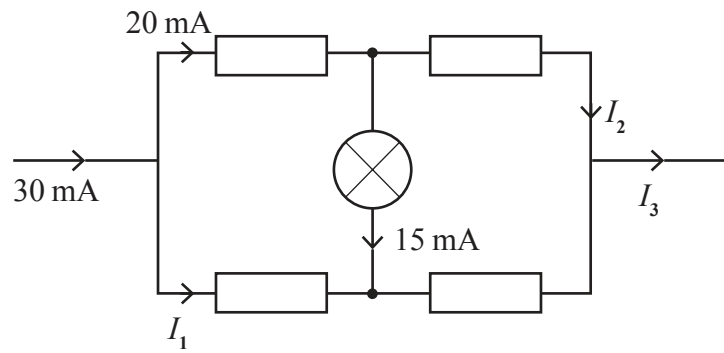

Determine the magnitudes of the currents I_1 , I_2 and I_3 . (3)

$I_1 =$

$I_2 =$

$I_3 =$

(Total for Question 13 = 4 marks)

*14

15

n:

v:



***14** A student looks at the sunlight reflected off a puddle of water. She puts a polarising (Polaroid) filter in front of her eye. As she rotates the filter the puddle appears darker then lighter.

Explain this observation.

(3)

.....

.....

.....

.....

.....

.....

.....

(Total for Question 14 = 3 marks)

15 The current I in a length of aluminium of cross-sectional area A is given by the formula

$$I = nevA$$

where e is the charge on an electron.

(a) State the meanings of n and v .

(2)

n :

v :

(b) Show that the units on the left hand side of the equation are consistent with those on the right hand side.

(3)

.....

.....

.....

.....

.....

.....

.....

(Total for Question 15 = 5 marks)



16 (a) Two lamps A and B are connected in series with a battery.

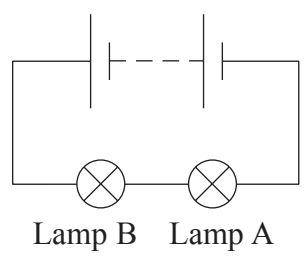

Lamp B glows more brightly than lamp A. Complete each of the sentences by choosing one of the phrases in the box.

(3)

equal to	greater than	less than
----------	--------------	-----------

- The current in lamp A is the current in lamp B.
- The p.d. across lamp A is the p.d. across lamp B.
- The resistance of lamp A is the resistance of lamp B.

(b) The same bulbs are now connected in parallel with the battery.

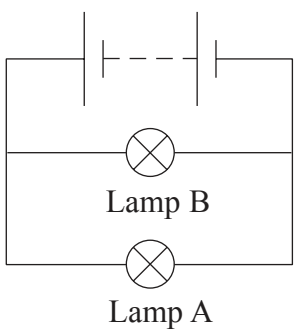

State which bulb will be brighter and explain your answer.

(3)

.....

.....

.....

.....

.....

(Total for Question 16 = 6 marks)



17 Two students demonstrate standing waves to the rest of the class using a rope.

The diagram shows the appearance of the standing wave on the rope at one instant. Each part of the rope is at its maximum displacement.

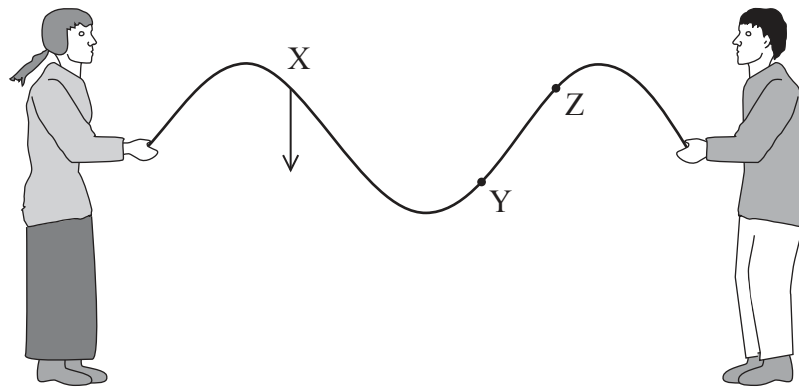

(a) (i) Mark the position of **one** node on the diagram. Label this point N. (1)

(ii) The arrow at point X shows the direction in which the point X is about to move. Add arrows to the diagram to show the directions in which points Y and Z are about to move. (2)

(b) The frequency of the vibration shown in the diagram is 1.5 Hz. When a rope is vibrating with its fundamental frequency there is one antinode. Calculate the fundamental frequency of this wave. (2)

.....

Frequency =

(Total for Question 17 = 5 marks)



18 Noise cancelling headphones were first invented to cancel the noise in aeroplane and helicopter cockpits. They work using the principle of superposition of waves.



Sound waves enter and pass through the headphone and are detected by a microphone. An electronic circuit sends a signal to the loudspeaker so that it produces an 'opposite wave'.

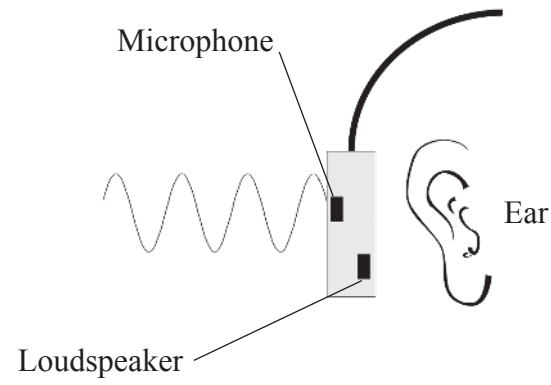

(a) Compare the properties of the two sound waves necessary to produce complete cancellation of the two waves that reach the ear.

(3)

.....

.....

.....

.....

.....

.....



(b) In practice the incoming sound is reduced in volume rather than cancelled completely.

Noise-cancelling headphones work well when the noise is from a jet engine. They are not very effective at cancelling speech or music. Explain why.

(3)

.....

.....

.....

.....

.....

.....

.....

(Total for Question 18 = 6 marks)



*19 (a) A 60 W filament light bulb is used as a ceiling light. The bulb is 2.5 m above the floor and is 5.0% efficient at converting electrical energy into visible light.

Calculate the visible light intensity (radiation flux) on the floor directly below the bulb.

Assume that at a distance r from the source the energy is spread over a total area $4\pi r^2$.

(3)

.....
.....
.....

Visible light intensity =

(b) Increasingly a different type of light bulb is being used. It is a coiled fluorescent bulb. A 10 W bulb of this type could replace the 60 W filament bulb and give the same visible light intensity on the floor.



Approximately 25% of national power production is used for lighting.

Discuss why some countries have announced that filament bulbs will be banned in the next few years.

(3)

.....
.....
.....
.....
.....

(Total for Question 19 = 6 marks)



20 A sonic tape measure uses ultrasound to measure distances in buildings. It sends out pulses of ultrasound towards a distant wall and records the time interval between a pulse being sent and its return.

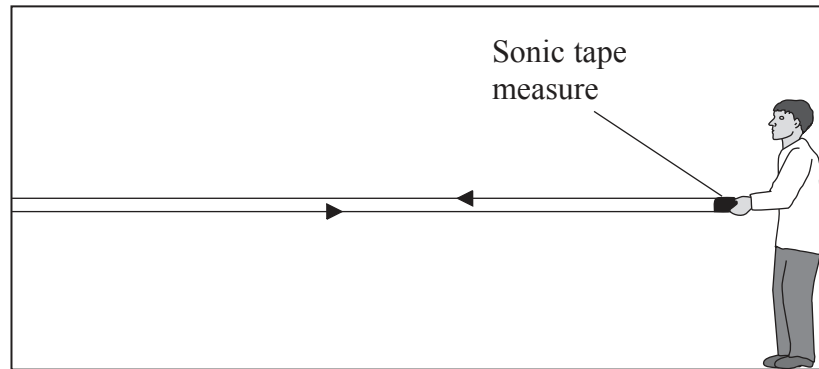

(a) For one particular measurement the time interval was 25 ms.

Calculate the distance from the sonic tape measure to the wall.

Speed of sound = 330 m s^{-1}

(3)

.....
.....
.....

Distance =

(b) Why is the ultrasound transmitted in pulses?

(1)

.....
.....

(Total for Question 20 = 4 marks)

.....
.....
.....
.....
.....
.....



21 An electronics student is using light emitting diodes (LEDs) to make a traffic light model. He uses red, orange and green LEDs. The table gives information about these LEDs. They are identified as 1, 2 and 3.

LED	Frequency / 10^{14} Hz	Wavelength / 10^{-9} m	Colour
1	5.66	530	
2	5.00	600	
3	4.41	680	

(a) Complete the table by filling in the colour of light emitted by each LED. (1)

(b) Calculate the energy of the lowest energy photon emitted by this traffic light model. (3)

.....

.....

.....

.....

.....

Energy =

(Total for Question 21 = 4 marks)



BLANK PAGE



17
Turn over ▶

- 22 A solar cell generates an e.m.f. when certain wavelengths of light are incident on it. A student connects a solar cell in the following circuit.

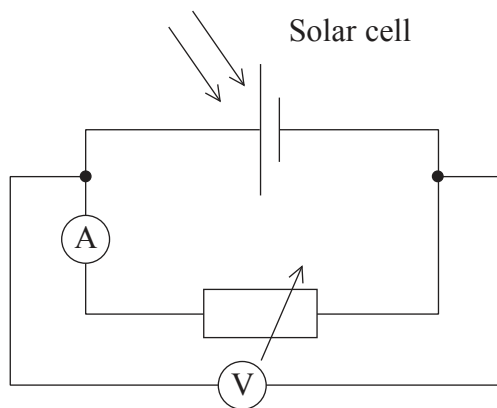

The student keeps the intensity and wavelength of the incident light constant and adjusts the variable resistor to obtain the following set of results.

Current I/A	Terminal potential difference V/V
0.60	0.00
0.55	0.35
0.50	0.40
0.40	0.43
0.30	0.46
0.20	0.48
0.10	0.50
0.00	0.52

- (a) On the grid opposite, plot these results and draw the line of best fit through all the points. The first four points have been plotted.

(3)



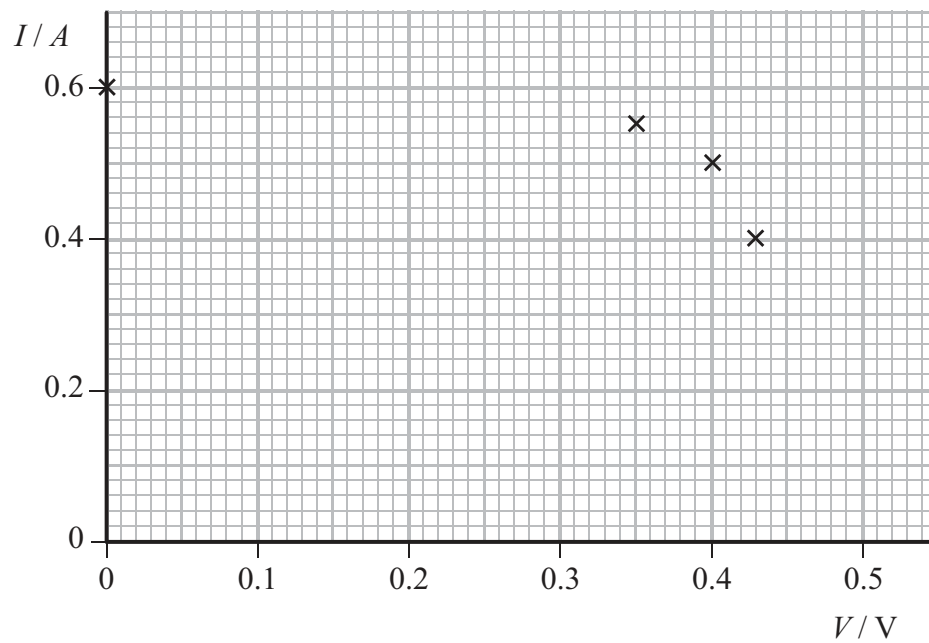

(b) (i) Calculate the power output of the solar cell when the current in the cell is 0.40 A.

(2)

.....

Power =

(ii) Explain why the e.m.f. of this cell is 0.52 V.

(2)

.....

(iii) Calculate the internal resistance of the cell when the potential difference across the cell is 0.40 V.

(3)

.....

Internal resistance =

(c) The e.m.f. of this particular cell is independent of the light intensity. The current increases as the light intensity increases.

Add to the grid above a line showing a set of results that might be obtained if the intensity of the incident light was increased.

(2)

(Total for Question 22 = 12 marks)



23 The diagram shows the apparatus for an experiment on the photoelectric effect.

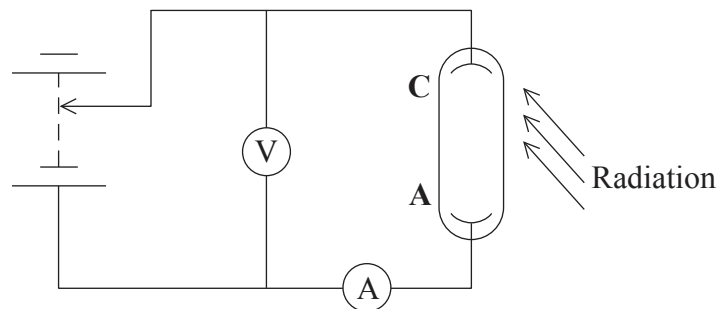

- (a) A light is shone onto the cathode C and a potential difference is applied between the cathode and the anode A of the photocell. A sensitive ammeter is used to detect any current that flows.

The light is replaced by one of the same intensity, but a different photon energy. The results are shown in the table below.

	Photon energy / eV	Intensity of light / W m^{-2}	Work function / eV	Ammeter reading / A
First light	1.8	1.0	2.3	0.0
Second light	3.8	1.0	2.3	5.0×10^{-12}

Explain why the first ammeter reading is zero.

(2)

.....

.....

.....

.....

- (b) The experiment is repeated using the same two photon energies but the intensities of the sources are increased. Add the new ammeter readings to the table below.

(2)

	Photon energy / eV	Intensity of light / W m^{-2}	Work function / eV	Ammeter reading / A
First light	1.8	4.0	2.3	
Second light	3.8	4.0	2.3	



(c) (i) The cathode metal is lithium.

Express the work function of lithium in joules.

Work function of lithium = 2.3 eV

(2)

Work function = J

(ii) Ultraviolet radiation with photon energy of 4.8×10^{-18} J is shone onto the lithium cathode.

Calculate the maximum speed of the photoelectrons that are emitted.

(4)

Maximum speed =

(Total for Question 23 = 10 marks)

TOTAL FOR SECTION B = 70 MARKS

TOTAL FOR PAPER = 80 MARKS



List of data, formulae and relationships

Acceleration of free fall	$g = 9.81 \text{ m s}^{-2}$	(close to Earth's surface)
Electron charge	$e = -1.60 \times 10^{-19} \text{ C}$	
Electron mass	$m_e = 9.11 \times 10^{-31} \text{ kg}$	
Electronvolt	$1 \text{ eV} = 1.60 \times 10^{-19} \text{ J}$	
Gravitational field strength	$g = 9.81 \text{ N kg}^{-1}$	(close to Earth's surface)
Planck constant	$h = 6.63 \times 10^{-34} \text{ J s}$	
Speed of light in a vacuum	$c = 3.00 \times 10^8 \text{ m s}^{-1}$	

Unit 1

Mechanics

Kinematic equations of motion	$v = u + at$ $s = ut + \frac{1}{2}at^2$ $v^2 = u^2 + 2as$
Forces	$\Sigma F = ma$ $g = F/m$ $W = mg$
Work and energy	$\Delta W = F\Delta s$ $E_k = \frac{1}{2}mv^2$ $\Delta E_{\text{grav}} = mg\Delta h$

Materials

Stokes' law	$F = 6\pi\eta rv$
Hooke's law	$F = k\Delta x$
Density	$\rho = m/V$
Pressure	$p = F/A$
Young's modulus	$E = \sigma/\epsilon$ where Stress $\sigma = F/A$ Strain $\epsilon = \Delta x/x$
Elastic strain energy	$E_{\text{el}} = \frac{1}{2}F\Delta x$

Un
Wa

Ele

Qu



Unit 2

Waves

Wave speed $v = f\lambda$

Refractive index ${}_1\mu_2 = \sin i / \sin r = v_1 / v_2$

Electricity

Potential difference $V = W/Q$

Resistance $R = V/I$

Electrical power, energy and efficiency
 $P = VI$
 $P = I^2R$
 $P = V^2/R$
 $W = VIt$

$$\% \text{ efficiency} = \frac{\text{useful energy output}}{\text{energy input}} \times 100$$

$$\% \text{ efficiency} = \frac{\text{useful power output}}{\text{power input}} \times 100$$

Resistivity $R = \rho l/A$

Current
 $I = \Delta Q / \Delta t$
 $I = nqvA$

Resistors in series $R = R_1 + R_2 + R_3$

Resistors in parallel
 $\frac{1}{R} = \frac{1}{R_1} + \frac{1}{R_2} + \frac{1}{R_3}$

Quantum physics

Photon model $E = hf$

Einstein's photoelectric equation
 $hf = \phi + \frac{1}{2}mv_{\text{max}}^2$



N 3 4 4 3 2 A 0 2 3 2 4

BLANK PAGE

